

2019 FMA Annual Meeting 23 - 26 October New Orleans, LA

Sponsorships
Exhibits
Advertising

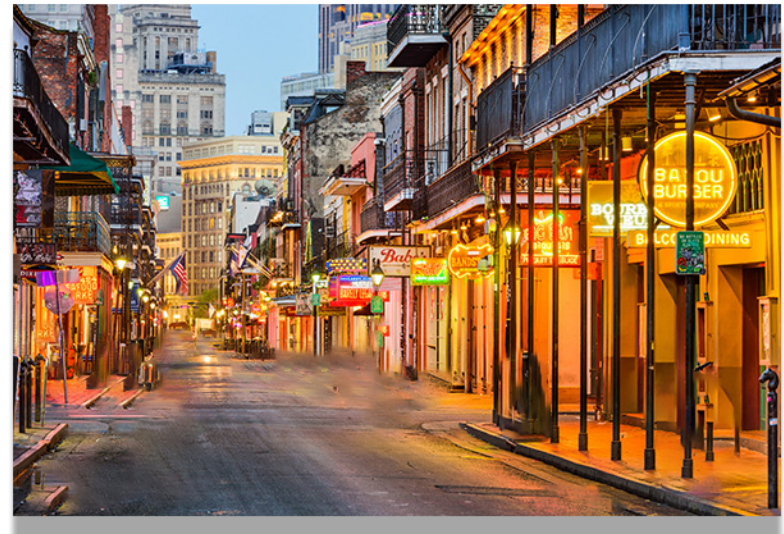

THE FINANCIAL MANAGEMENT ASSOCIATION INTERNATIONAL INVITES YOU ...

Over 1,700 gathered in San Diego, CA last October to present and discuss the latest research across all topics in finance.

The 2019 Annual Meeting in New Orleans, LA, 23 – 26 October is shaping up to be even bigger than last year. We are organizing a full agenda of academic and practitioner research sessions, special tutorials and panel sessions on cutting edge topics as well as the Keynote Address by Cam Harvey, Duke University and a number of very special networking events.

Exhibiting is an excellent way to reach your target audience and develop new contacts. To further highlight your company's products and services, we also offer numerous sponsorship opportunities.

We hope you will join us in New Orleans!

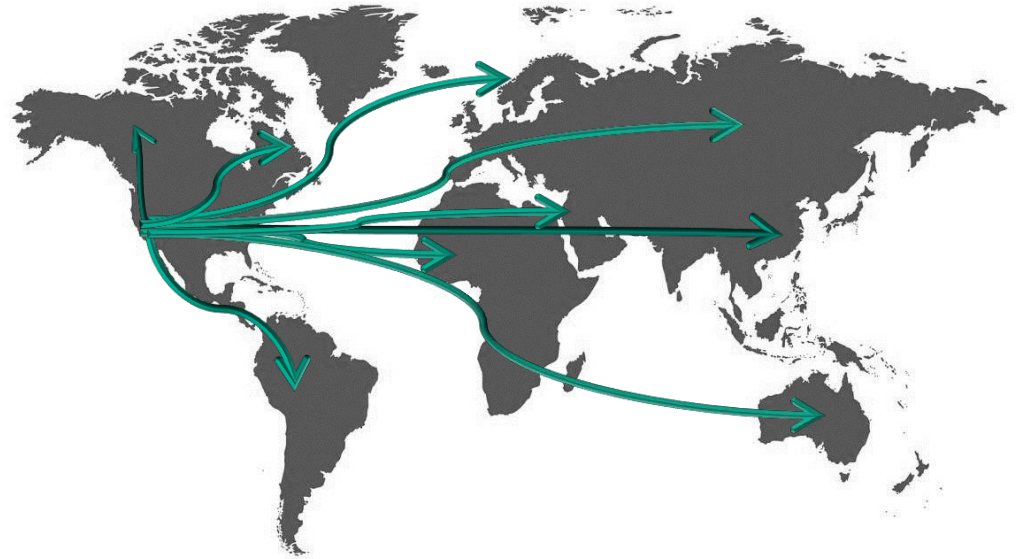

OUR ATTENDEES

Over 1,700 registrants attended the 2018 Annual Meeting in San Diego from around the world, representing:

- Over 700 academic and practitioner organizations
- 48 states plus the District of Columbia
- 33 countries including

US, Australia, Austria, Azerbaijan, Belgium, Brazil, Canada, China, Denmark, Finland, France, Germany, Hong Kong, India, Ireland, Italy, Japan, Kuwait, Mexico, New Zealand, Nigeria, Portugal, Republic of Korea, Russia, Saudi Arabia, Singapore, Spain, Sweden, Taiwan, The Netherlands, Turkey, Ukraine, United Arab Emirates, United Kingdom

SPONSOR BENEFITS

BENEFITS	PLATINUM	SILVER	BRONZE
One (1) complimentary booth rental in premier location	✓		
Sponsor recognition on the conference website	✓	✓	✓
Sponsor recognition on the conference app	✓	✓	✓
Acknowledgement at the Keynote Address and Friday Luncheon	✓	✓	
Signage prominently displayed onsite at key traffic areas throughout the conference	✓	✓	
Complimentary conference registrations	7	5	3

SPONSORSHIP OPPORTUNITIES

Attendee Wireless All attendees will be provided with an exclusive login that directs them to a personalized splash page with your company's logo and link to your website	\$15,000 One or split sponsorships available
Thursday Reception	\$15,000 One or split sponsorships available
Doctoral Student Consortium	\$10,000 One or split sponsorships available
Friday Reception	\$10,000 One or split sponsorships available
Conference App (filled)	\$8,000 One of split sponsorships available
Wednesday Reception (filled)	\$8,000 One or split sponsorships available
Exhibit Hall Networking/Recharge Lounges	\$4,000 One or split sponsorships available
Women's Networking Luncheon	\$4,000
Keynote Address (filled)	\$2,000
Assistant Professors' Breakfast	\$2,000
Best Paper Awards Corporate Finance (Filled) Derivatives and Options (Filled) Financial Markets and Institutions (Filled) Investments (Filled) Market Microstructure (Filled)	\$1,000 per award

EXHIBIT OPPORTUNITIES

Premier location (reserved for Platinum Level sponsors)	\$2,500
Standard location	\$1,500



EXHIBIT INFORMATION

Exhibit Space Assignment

Assignment of space is on a first-come, first-served basis. Please provide up to four (4) alternate selections of space on the Order Form. Refer to the diagram in this brochure for booth numbers and locations. FMA reserves the right to make appropriate changes in exhibitor locations as it deems necessary for the overall success of the Exhibit.

Exhibit Space Rentals

Exhibit booths are 10' x 10'. Exhibit space includes an 8' backwall drape, 3' siderails and an identification sign (drape colors are black (backwall) and grey (sidewalls)). All booth furnishings, booth carpeting, electrical and telephone connections, and special equipment are the sole responsibility of the exhibitor.

Location

The Exhibit Hall will be located in the Napoleon Ballroom BC of the Sheraton New Orleans; the room is fully carpeted.

Schedule

Set Up: Wednesday, October 23, 12:00 noon - 5:00 pm (late access is possible)

Tear Down: Friday, October 25, 5:01 p.m. – 9:00 p.m.

Show Days and Times

Thursday, 24 October & Friday, 25 October: 8:00 a.m. – 5:00 p.m.

Drayage Services

All drayage and decorating services will be handled by Freeman. Exhibitors will receive a link to the drayage and decorating kits via Freeman.com in summer, 2019.

Hotel Reservations

Sheraton New Orleans Hotel reservations are available [here](#).

Room rates are \$259 (plus service charges and taxes), single or double occupancy

Security

As a courtesy to exhibitors, security guard services will be offered during the following hours:

Tuesday, 22 October: 5:00 pm - 8:00 am

Wednesday, 23 October: 5:00 p.m. - 8:00 a.m.

Thursday, 24 October: 5:00 p.m. - 8:00 a.m.

The presence of security is a courtesy and does not constitute an admission of responsibility by either the Financial Management Association or the Sheraton New Orleans Hotel for booth contents.

Nature of the Annual Meeting Exhibits

The Annual Meeting is an educational and research-oriented conference of a scientific nature. The Annual Meeting exhibits are designed to complement the aspects of the Annual Meeting sessions. The goal of the Association in sponsoring exhibits at the Annual Meeting is to provide another avenue for the exchange of ideas and information on existing educational technologies and applications, new concepts and innovative designs, and the availability of products and services.

Qualifications:

Eligibility is limited to exhibitors whose products are deemed to be of interest to attendees of the FMA Annual Meeting. All applicants are required to submit the nature of their business and the scope of their products and/or services to be exhibited. This and other information are required on the **Exhibitor Application**, which must be completed by each vendor seeking to exhibit at conference. FMA reserves the right to reject any application to exhibit.

Proper Use of Exhibit Space

The space contracted for is to be used solely for the Exhibitor whose name appears on the Exhibitor Application. Exhibitors may not reassign, sublet, or allow other companies to use the whole or a part of the space assigned by FMA without written consent of FMA. Exhibitors may not display or advertise any goods or services not manufactured, distributed, or otherwise provided by the exhibiting company during the normal course of business. All displays, demonstrations, sales activities, etc., must be contained within the booth space. Exhibitors may not impede traffic through the aisles. FMA policy restricts representatives or organizations that have not been assigned an official exhibit booth space from soliciting business and from distributing promotional materials of any type within the Exhibit Hall area or any other areas. Those caught doing so will be immediately asked to leave.

Sales and/or Solicitation of Orders

Sale of products and services is allowed on the exhibit floor provided such sales are conducted in a professional, businesslike manner and the exhibitor complies with all state and local tax regulations. FMA reserves the right to restrict sales activities that it deems inappropriate or unprofessional.

Violations of Rules and Regulations

FMA reserves the right to remove exhibits that may have been falsely , or may be deemed unsuitable, objectionable or detract from the general order of exhibits. Violations of these rules and regulations will afford FMA the right to prohibit Exhibitor from exhibiting at the current year's conference (in which case Exhibitor shall forfeit its booth payments) and/or prohibit Exhibitor from exhibiting at the following year's conference.

Indemnification

Exhibitor assumes the entire responsibility and liability for losses, damages, and claims arising out of injury to persons or damage to Exhibitor's displays, equipment, or other property brought upon the premises of the Hotel and agrees to indemnify, defend and hold harmless the Group, the Hotel and its owners, servants, agents, and employees against all claims or expenses for such losses, including reasonable attorney's fees, arising out of the use of the hotel premises excluding any liability caused by the negligence of the Group and the Hotel or its owners, servants, agents, or employees.

Exhibitor shall indemnify, hold harmless and defend the FMA, its directors, officers, agents and employees for and from any and all losses, claims, liability, damage, action, judgment recovered from or asserted against them or other expense (including, without limitation, attorney's fees and expense) arising out of or relating to the Exhibitor's use of the Exhibit Hall or from the conduct of the Exhibitor's business or from any activity, work or things which may be permitted or suffered by the Exhibitor's in or about the Exhibit Hall or from any breach or default in the performance of any obligation on the FMA's part to be performed under any provision of the agreement or arising from any negligence of the Exhibitor or any of its agents, contractors, employees or invitees, including, but not limited to, the use of patented, trademarked or copyrighted materials, equipment, devices, processes or dramatic rights furnished to or used by the Exhibitor or other persons in connection with the FMA's use of the Exhibit Hall. The Exhibitor hereby assumes all risk of damage to its property placed in the Exhibit Hall or injury to its officers, directors, employees, agents, contracts, invitees or any attendees at the Conference or in or about the Exhibit Hall from any cause, and hereby waives all claims in respect thereof against the FMA except to the extent such damage results directly from the negligence of the FMA.

Liability: The exhibitor assumes the entire responsibility and liability for losses, damages, and claims arising out of exhibitor's activities on the Hotel premises and will indemnify, defend, and hold harmless the Hotel, its owner, and its management company, as well as their respective agents, servants, and employees from any and all such losses, damages, and claims.

Hotel will not be responsible or liable for any loss, damage or claims arising out of exhibitor's activities on the Hotel's premises except for any claims, loss, or damages arising directly from the hotel's own negligence.

FMA makes no guarantees and assumes no liability with regard to traffic through the exhibit area, sales by exhibitors, or other measures of profitability of the exhibits at this event.

Booth Usage - Audio Restrictions

The use of taped music (cassette tapes, CD's, MP3 players or streamed music) is not allowed in the Exhibit Hall at any time unless the Exhibitor holds an exclusive licensing agreement with the music provider. Proof of this licensure must be provided to the FMA prior to show opening.

Nondiscrimination

Exhibitor agrees to comply with all federal, state and local laws prohibiting discrimination by reason of race, color, age, sex, marital status, sexual orientation, political ideology, creed, religion, ancestry, national origin or the presence of any sensory, mental or physical handicap or the use of a trained guide dog by a blind, deaf or physically disabled person.

Laws and Requirements

Exhibitor will comply with all laws of the United States and the State of California; all municipal ordinances; and all lawful orders of police and fire departments or any other municipal authority; and will obtain, and pay for, all necessary permits, taxes and licenses; and will not do nor suffer to be done anything on said premises during the exhibition hours (included set-up and dismantle hours) in violation of any laws, ordinances, rules or orders.

Cancellation of Lease

The Exhibitor shall have the right to cancel this agreement at any time by written notice to FMA. If such cancellation is received prior to 16 August 2019, FMA shall refund any payments already made by the exhibitor. In the event that rental is canceled after 16 August 2019, FMA will refund rental payments made by the exhibitor only if the space can be re-rented at no loss to FMA.

CONFERENCE APP AND PRINT PROGRAM ADVERTISING INFORMATION

Banner Ad Specifications

- Please provide an Image file in .png format at 640w x 160h or 680w x 80h (72dpi).
- Text must be readable at a 320w x 80h resolution
- File submission deadline: **6 September 2019**

Print Ad Specifications

Please provide an image or PDF file with an 8" (W) x 10.5" (H) trim size with no bleeds

Program ads will be printed in black and white; the online program will contain color ads. Please keep in mind that color ads which are converted to a black and white print may print at a lower resolution.

File submission deadline: **6 September 2019**

Advertising Prices

All Media (print ad plus banner ad): \$1,000

Print Ad only: \$750



2019 FMA ANNUAL MEETING EXHIBIT HALL

Napoleon Ballrooms BC

[Click here to make your sponsorship, exhibit or ad reservation](#)

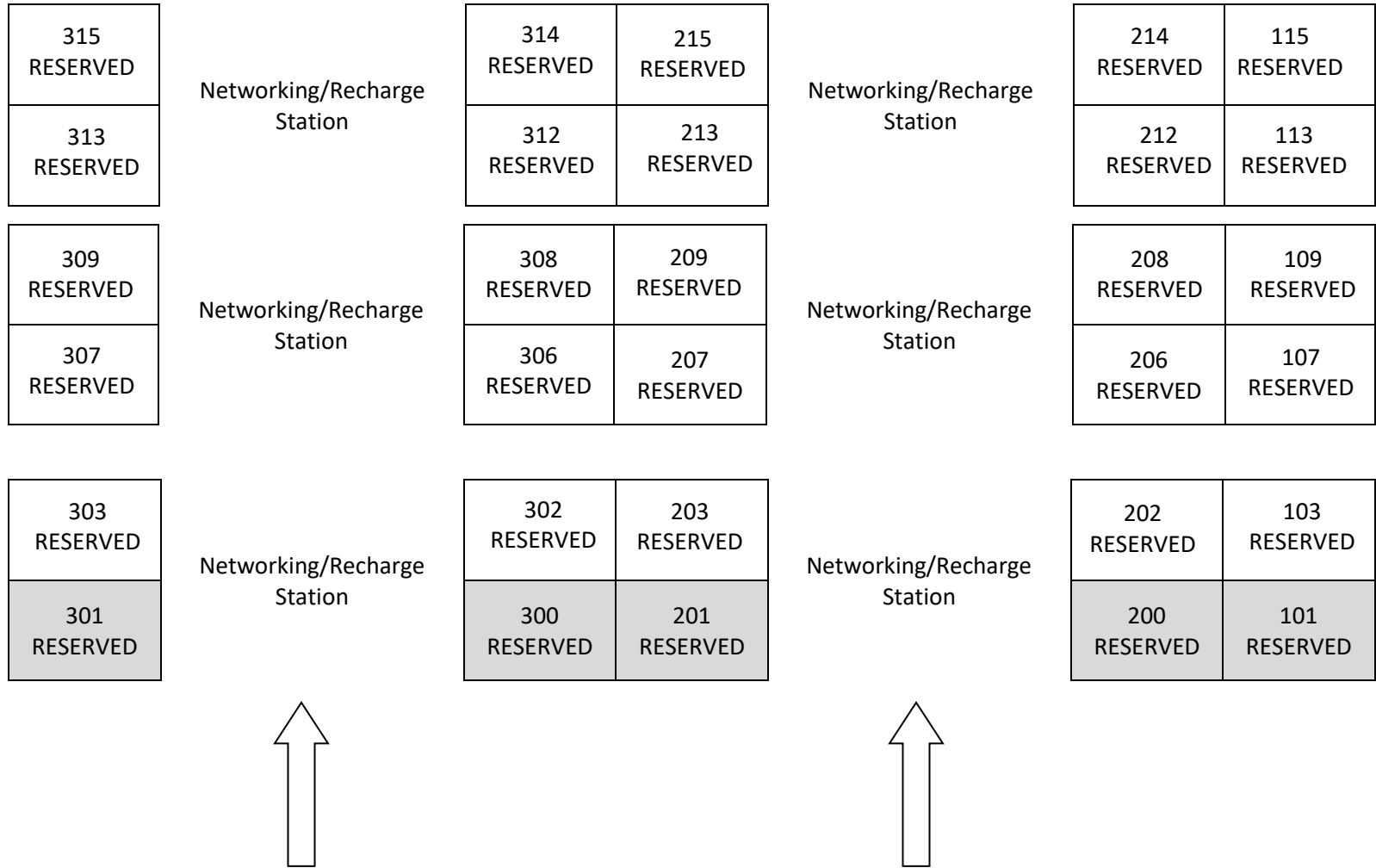

Floor plan is not to scale, Networking/Recharge Station locations subject to change. Conference Registration location is TBA.